

Donaldson®
Torit®

TORIT® POWERCORE®
DUST COLLECTORS
CP SERIES

 **PowerCore®**
Smaller. Smarter Collectors.™



Processing's
**Breakthrough
Product of 2008**

...Processing Magazine



Donaldson.com/ToritPowerCore

SMALLER. SMARTER DUST COLLECTORS

Torit® PowerCore® dust collection technology from Donaldson® Torit® outperforms traditional baghouse collectors and does so in less space. In one extremely small and powerful package, the Torit PowerCore dust collector handles high airflow, high grain loading, challenging particulate and fits into the smallest places. The filter changeout is remarkably quick, easy and clean compared to the process for traditional filter bags.

Innovative Torit PowerCore dust collectors combine award-winning PowerCore Filter Packs™ with a new and patented compact pulse cleaning system. This proprietary combination delivers high filtration efficiencies not usually found in baghouse filtration.

TORIT POWERCORE

- **SMALLER**
- **SMARTER**
- **CLEANER**
- **EASIER**
- **COST EFFECTIVE**



(5000 cfm collectors)
Torit PowerCore CPC-12
vs. Traditional (81) 8-ft. filter baghouse

OUTPERFORMS TRADITIONAL BAGHOUSE COLLECTORS

Today's streamlined and lean manufacturing facilities demand peak performance even within the smallest spaces. Torit PowerCore space-saving dust collectors are available as stand-alone models that can be ducted to many different applications, as well as bin vent models used on applications like silos, conveyor transfer points, conveyor discharges, blenders and mixers.

Compared to traditional baghouse collectors with similar airflow capacities, Torit PowerCore CPC dust collectors (as shown on previous page) are up to 50% shorter. The comparison to traditional bag-style bin vents is even more dramatic. CPV bin vent collectors are almost 70% shorter than other bag-style bin vents and effectively address the frequent challenge of tight space limitations.

- **SMALLER**

Bin vents fit into the tightest spaces.

- **CLEANER**

PowerCore Filter Packs with Ultra-Web® technology provide higher efficiency for cleaner air. Plus, replacing PowerCore Filter Packs is a remarkably clean process.

- **EASIER**

Clean-side filter access and fewer, lighter filters means faster, easier filter changes without tools or filter cages.

- **SMARTER**

An optimized airflow management system delivers optimal pulse cleaning while minimizing airflow restriction.

- **COST EFFECTIVE**

Innovative PowerCore filtration technology means reduced freight and installation costs, fewer filter changeouts, lower maintenance costs, and no entry requirements for filter changes.



(1500 cfm collectors)

Torit PowerCore CPV-3
vs. traditional bin vent

SMALLER. SMARTER FILTERS.**POWERCORE FILTER PACK—NOT A BAG, NOT A CARTRIDGE**

An entirely new approach to dust collectors, the PowerCore Filter Pack is small, lightweight, and easily handled by one person. Donaldson's PowerCore technology allows more effective filter area to be packaged in a smaller space: one 7" x 22" PowerCore Filter Pack contains as much filtering area as 6 eight-foot-long traditional filter bags. And the filter media inside PowerCore Filter Packs is our well-proven Ultra-Web advanced nanofiber technology.

POWERCORE FILTER PACK

- Changeout from the clean side of the collector—only 1 person required.
- Self-centering with a handle for easy changes without tools.
- Integrated gasket ensures a good seal with every change.
- At only 7" tall, bridging is not a problem.

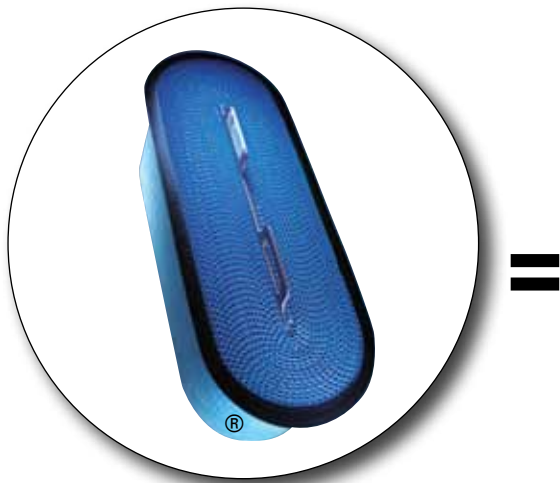
**=**

Just one 7-inch deep PowerCore Filter Pack replaces six 8-ft. long filter bags.

Smaller is Smarter.

INNOVATIVE MEDIA CONFIGURATION TECHNOLOGY

LEADING THE WAY WITH POWERCORE

At the Core is PowerCore. PowerCore Filter Packs combine patented Ultra-Web nanofiber technology with Donaldson’s media configuration expertise. The result is a revolutionary filtration technology unlike anything else in the industrial filtration market.

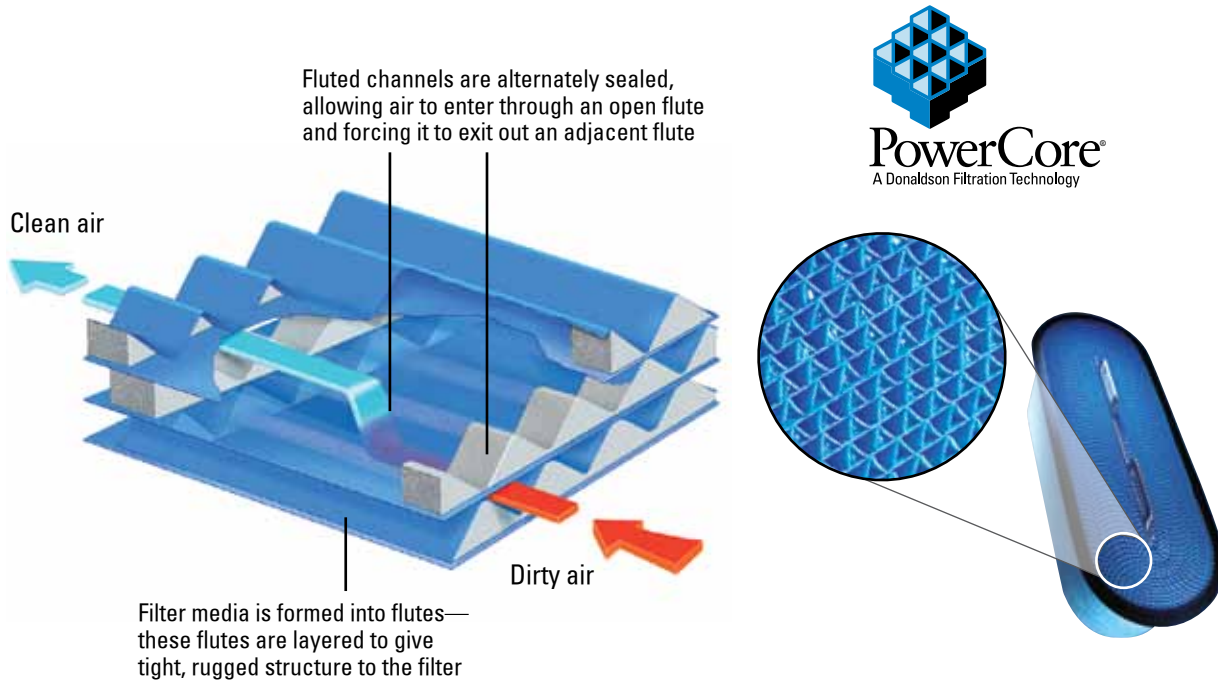

HIGH PERFORMANCE FILTER MEDIA

In a dramatic departure from the traditional filter bag, the PowerCore Filter Pack contains Ultra-Web media, which traps more dust on the surface of the fluted channels as compared to conventional filter bag materials like depth-loading 16 oz. polyester. Surface loading greatly promotes filter cleaning. Better pulse cleaning lowers operational pressure drop and energy use.

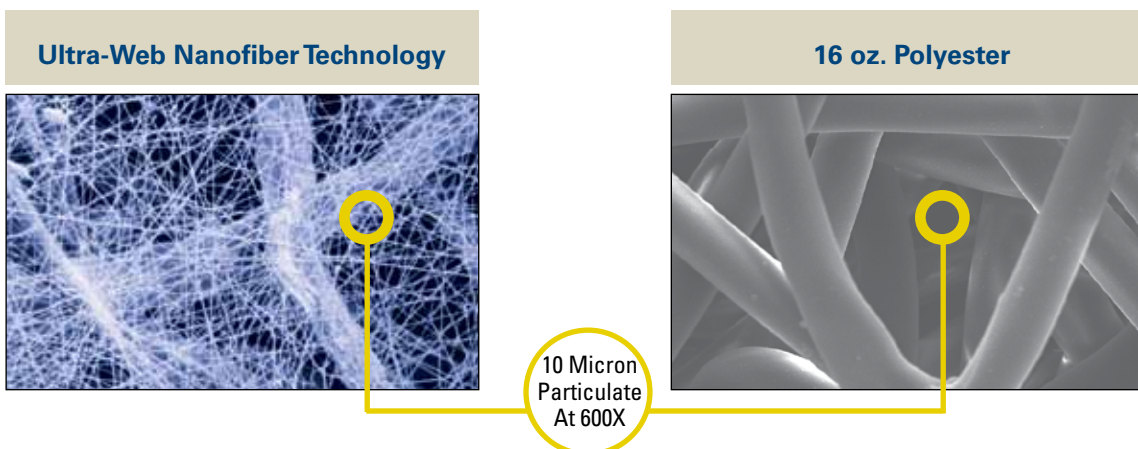

POWERCORE FILTER PACKS—ENGINEERED TO PERFORM

TECHNOLOGY THAT PERFORMS FOR OVER 25 YEARS

Donaldson Torit Ultra-Web technology has delivered high efficiency filters that last. PowerCore Filter Packs with Ultra-Web are engineered to perform, balancing high efficiencies with long filter life.

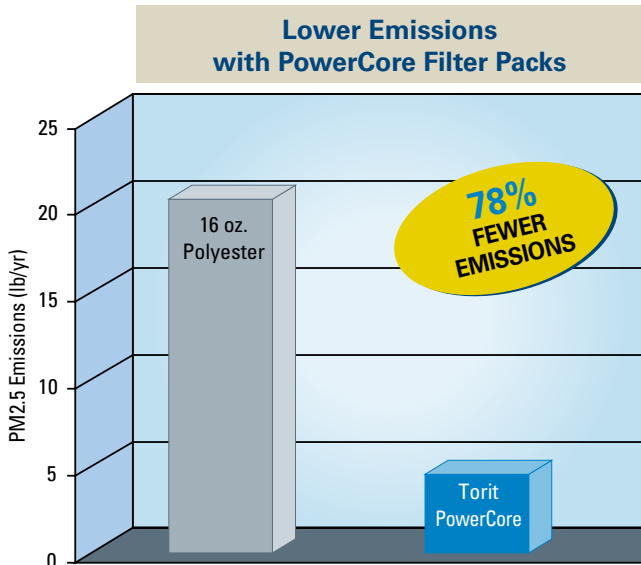

Independent lab results obtained using ASTM D6830-02 per EPA PM 2.5 performance verification. Annual emissions calculated assuming 14,400 cfm airflow rate, 265 working days per year, and two shifts per day. Field measurements may vary due to differences in dust contaminant and sensitivity of measurement equipment.

OUTSTANDING PERFORMANCE

Torit PowerCore CP Series systems with PowerCore Filter Packs deliver outstanding performance with PM 2.5 emissions below 0.001 grains per cubic foot, per EPA Method 27 and EPA Method 5i.

Torit Powercore CP Series Filter Packs are efficiency rated MERV 13 per the ASHRAE 52.2-1999 test standard.



EASY ON THE BUDGET

The surface-loading technology of Ultra-Web is proven to provide lower operating pressure drop over a longer period of time, and energy costs can be dramatically reduced. Pressure drop starts high and rises quickly with traditional depth-loading filter bags, resulting most often in excessive energy use.

For proven technology that delivers savings in energy, maintenance, space, and filter changes, the smartest solution is Torit PowerCore.

Surface Loading Allows Downsizing

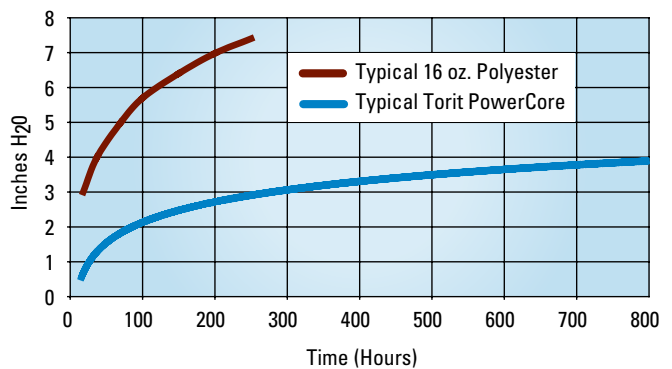

The results from accelerated lab and field tests show that Torit PowerCore can provide lower pressure drop in baghouse applications.

OPTIMIZED AS A SYSTEM

SMARTER FILTER CLEANING

Torit PowerCore collectors include a new patented compact pulse cleaning system designed to match the pulse energy to the obround shape of the PowerCore Filter Pack. The resulting pulse flow effectively covers the entire media pack. It easily pulses the dust out of the fluted channels, keeping the pressure drop low and prolonging filter life.

**Compact Pulse Cleaning System
CPV-1**



**Compact Oblique Pulse Cleaning System
CPV-2 through CPV-12**

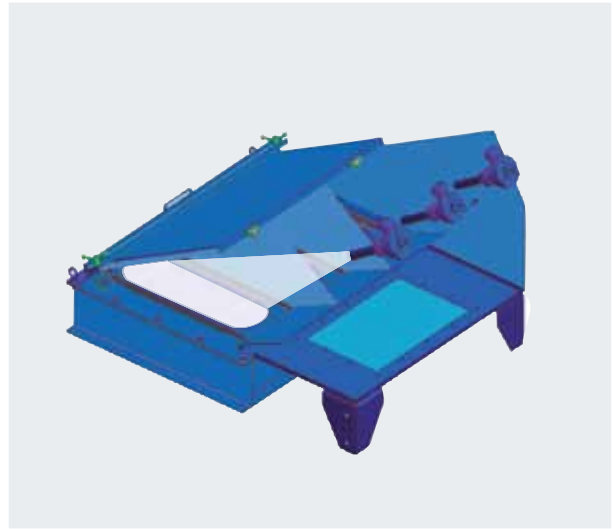

SOPHISTICATED MODELING

Providing optimized pulse cleaning, the pulse accumulator design is based on Donaldson Torit's commitment to technical research and development. FLUENT®* Airflow Modeling Software was used to determine the shape of the pulse accumulators to optimize the pulse energy without restricting the airflow or wasting energy. The pulse accumulators, used on the CPV-2 through CPV-12, also serve as a filter retention mechanism, securing the Filter Pack in place and ensuring optimum gasket compression.

**Pulse Accumulator
Optimizes Pulse & Seals Filter Pack**



Pulse accumulator

* FLUENT is a registered trademark of Fluent, Inc.

MAKING MAINTENANCE EASIER

SMALLER, BETTER, SMARTER

Torit PowerCore can reduce your cost of dust collection resulting in significant operational savings. An application previously requiring (81) 8-foot filter bags now needs only (12) 7-inch-tall PowerCore Filter Packs. Fewer filters mean lower filter changeout costs and faster changeouts. The smaller collector means lower installation costs and less factory floor or bin space consumption.

	Number of Filters in Collector	Time to Replace*	Labor Cost	Time Savings*	Labor Savings*
PowerCore Filter Packs	12	<i>Only 24 minutes</i>	\$18	<i>13.1 hours</i>	<i>\$590 Saved</i>
Traditional Filter Bags	81	13.5 hours	\$608	0	0

* Savings are based on one changeout. Calculations assume bags and PowerCore Filter Packs show equal life span; one person replacing one traditional filter bag in 10 minutes; one person changing PowerCore in 2 minutes; labor rates equal \$45/hr.

EASY MAINTENANCE

Replacing PowerCore Filter Packs is as easy as 1-2-3. Contrary to many traditional baghouse collectors, PowerCore Filter Packs are lightweight and accessed from the clean side of the collector. Easy. Fast. Clean. **No tools or cages required.**

PowerCore Filter Pack Replacement — Easy. Fast. Clean.

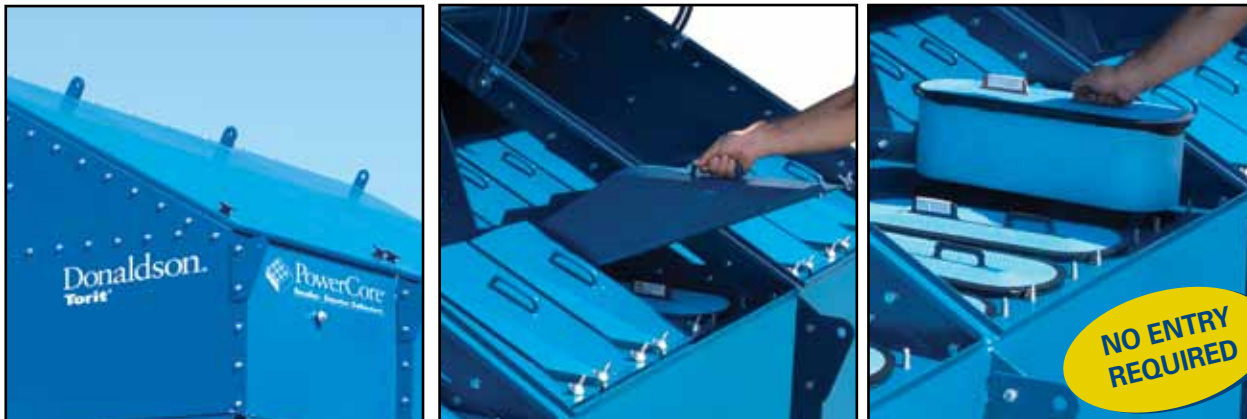

- 1 Lift up filter access door. (Clean side of the system)
- 2 Loosen the captive hardware and remove the filter retainer.
- 3 Lift out the Filter Pack for easy replacement.

HOW SMALLER MEANS SMARTER OPERATION

SMART RESULTS IN MANY WAYS

- Collectors weigh less, so shipping costs are lower.
- There are no filter bags or cages to ship and install separately.
- Easier Filter Pack changeouts save time and money.
- Airflow design prevents dust bridging between Filter Packs—less maintenance required.
- Airflow patterns minimize abrasion, preventing leaks and maintenance common with abrasive dust.



A CPV-2 is 70% smaller than a traditional bin vent making shipping easy and reducing freight costs.

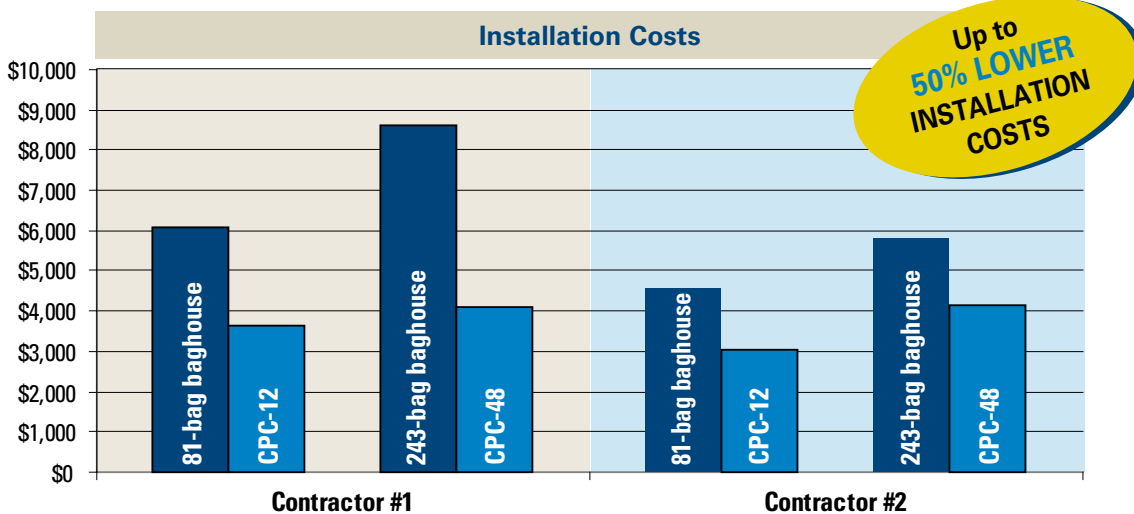

The Torit PowerCore system arrives mostly assembled, so installation is faster and easier. Installation costs are reduced 30-50% due to lighter weight, less crane time, and pre-assembly. The Filter Packs come pre-installed in the collector, so there are no bags or cages to install separately.

THE OPTIMIZED SOLUTION FOR MATERIAL HANDLING

SMARTER SOURCE FILTRATION

Torit PowerCore CPV bin vent collectors are easily integrated into a variety of material-handling applications—even in tight spaces—providing source filtration that saves money and energy. Source collection with Torit PowerCore can provide:

- Lower initial costs: freight, installation, and ducting are all reduced.
- Product will stay in the process, eliminating waste streams and costly recycle systems.
- Reduced energy consumption as air and dust aren't moved unnecessarily through long ducting runs.

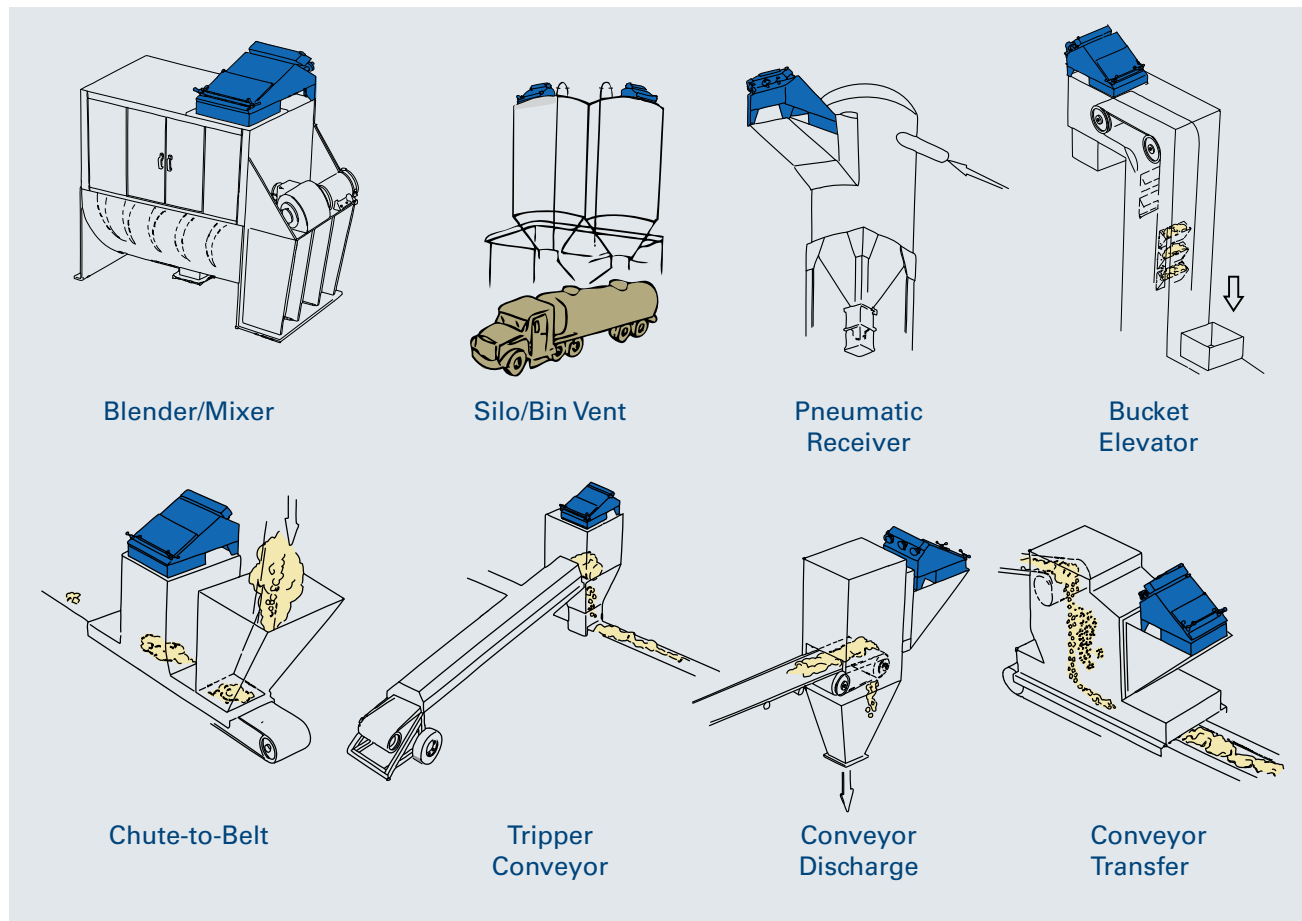

HOW THE CP SERIES WORKS

Normal Operation for CPV-1 Model

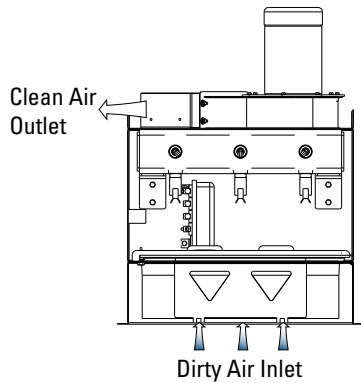

Filter Cleaning Operation for CPV-1 Model

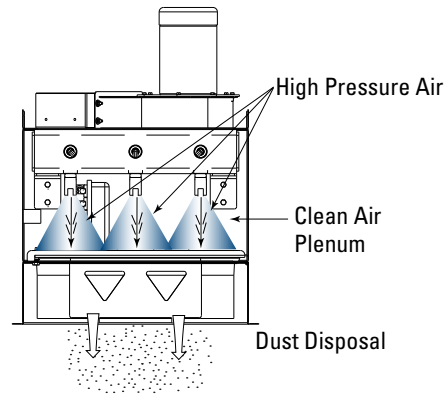

Normal Operation for CPC 2-48 Models

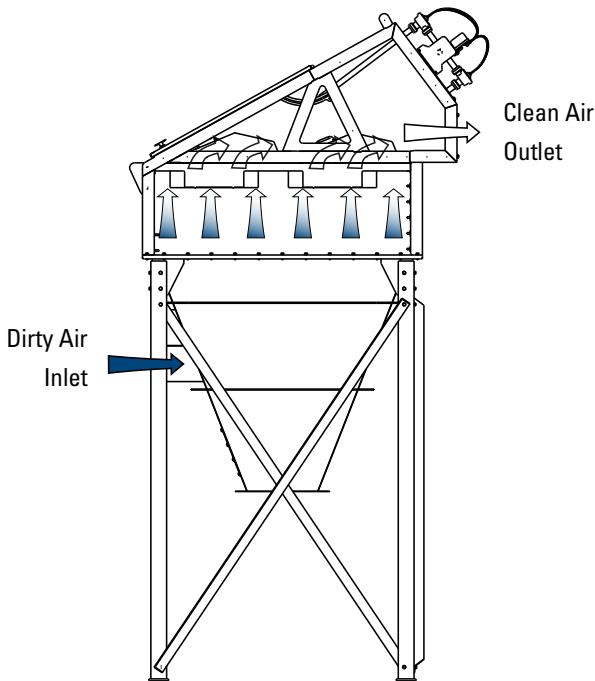

Filter Cleaning Operation for CPC 2-48 Models

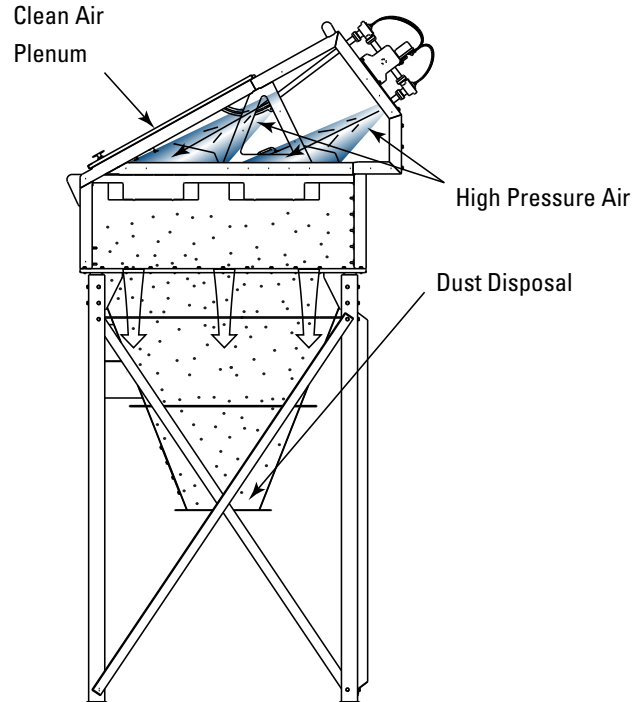

- Dust-laden air enters the collector through the dirty air inlet and is directed upward through the Filter Packs.
- Heavier particulate falls directly into the hopper or bin below.

- Air is filtered through the Filter Packs and directed out the clean air outlet.
- When pressure drop exceeds a pre-set point, the compact oblique pulse system sends a pulse of cleaning air back through the Filter Packs and thoroughly cleans the media flutes.

DIMENSIONS & SPECIFICATIONS

MODELS CPV-1

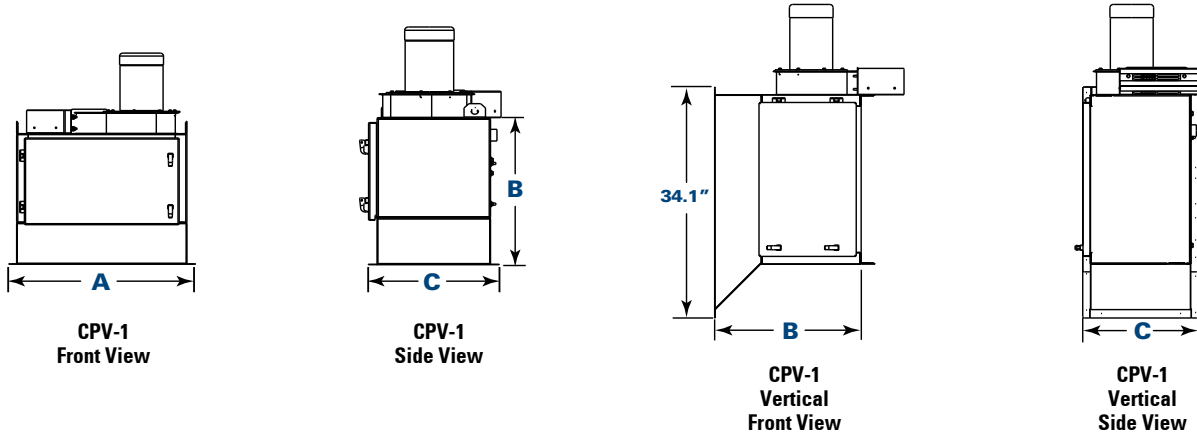

MODELS CPV-2 THROUGH CPV-12

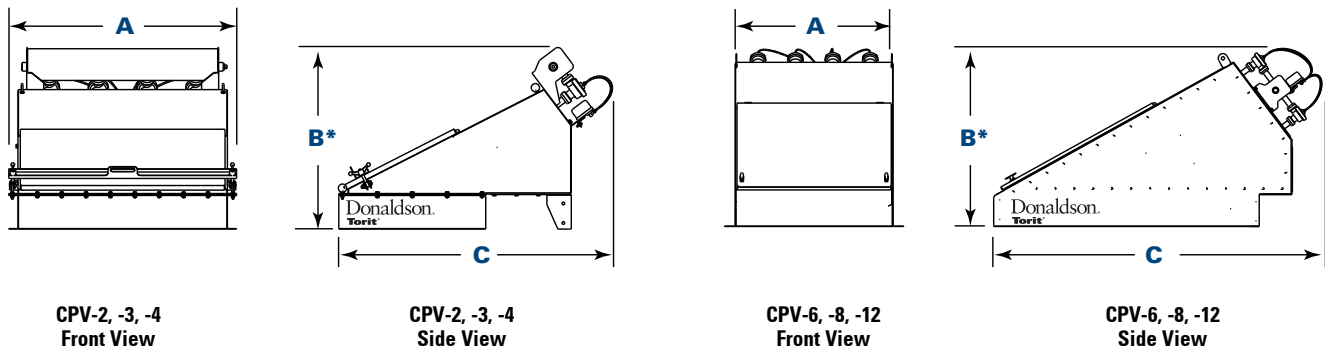

Model	Nominal Airflow Range** (cfm)	No. of Filter Packs	PowerCore Filter Area (ft²)	No. of Valves	Shipping Weight (lbs)	Housing Rating ("wg)	Dimensions (inches)		
							A	B*	C
CPV-1	up to 700	1	67	3	120 †	±12	27.1	22.3	17.6
CPV-2	450 - 1400	2	134	2	320	±20	26.8	37.2	47.7
CPV-3	700 - 2000	3	201	3	400	±20	36.8	37.2	47.7
CPV-4	1400 - 2700	4	268	4	500	±20	46.8	37.2	47.7
CPV-6	2100 - 4100	6	402	6	655	±20	32.2	46.1	83.6
CPV-8	2800 - 5400	8	536	8	800	±20	42.2	46.1	83.6
CPV-12	4200 - 8200	12	804	12	1130	±20	64.2	46.1	83.6

* For opening access door, allow a minimum of 2.5" above unit for models 2, 3, 4, and a minimum of 20.5" for models 6, 8, 12.

** Based on clean filters.

† Shipping weight with integral fan is 160 lbs.

OPERATING CONDITIONS FOR CP SERIES COLLECTORS

Seismic Spectral Acceleration	Ss +1.5 & S1= 0.6	Compressed Air Required (psig)	90-100
Wind Load Rating (mph)	90	Operating Temperature	180°F

DIMENSIONS & SPECIFICATIONS

MODELS CPC-3 through CPC-48

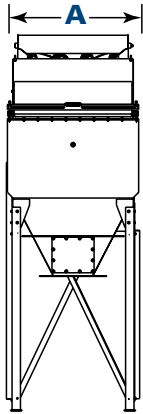

**CPC-3, -4
Front View**

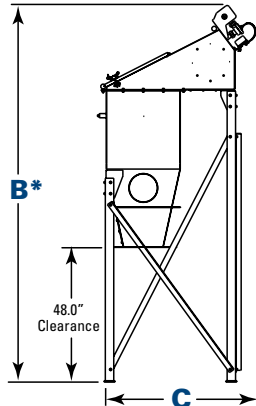

**CPC-3, -4
Side View**

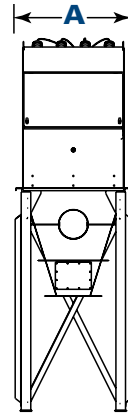

**CPC-6, -8, -12, -16
Front View**

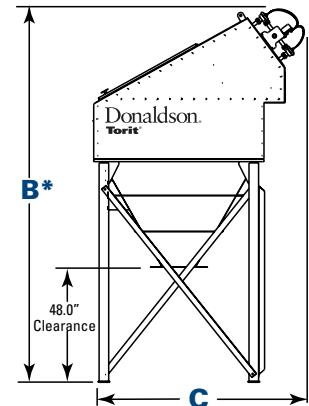

**CPC-6, -8, -12, -16
Side View**

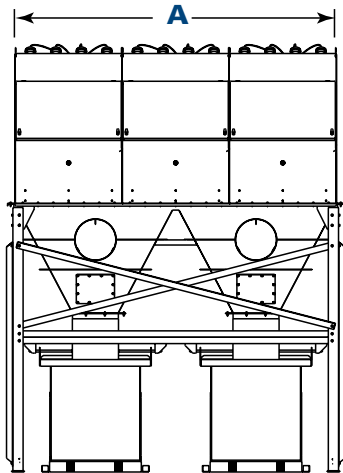

CPC-24 with optional dumpster hopper
Front View**

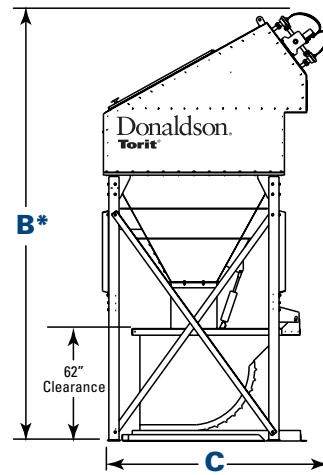

**CPC-24 with optional dumpster hopper
Side View**

Model	Nominal Airflow Range† (cfm)	No. of Filter Packs	PowerCore Filter Area (ft²)	No. of Valves	Shipping Weight (lbs)	Housing Rating ("wg)	Dimensions (inches)		
							A	B*	C
CPC-3	700 - 2000	3	201	3	900	-20	36.8	118.4	55.5
CPC-4	1400 - 2700	4	268	4	1100	-20	46.8	134.2	55.5
CPC-6	2100 - 4100	6	402	6	1300	-20	32.2	154.2	83.5
CPC-8	2800 - 5400	8	536	8	1685	-20	42.2	154.2	83.5
CPC-12	4200 - 8200	12	804	12	2100	-20	64.2	154.2	83.5
CPC-16	5600 - 11,000	16	1072	16	2915	-20	84.2	169.2	83.5
CPC-24	8400 - 16,500	24	1608	24	3880	-20	126.2	152.2	83.5
CPC-32	11,200 - 22,000	32	2144	32	5310	-20	168.2	169.2	83.5
CPC-40	14,000 - 27,000	40	2680	40	6210	-20	212.7	154.7	81.6
CPC-48	16,800 - 33,000	48	3216	48	7760	-20	252.2	169.2	83.5

* For opening access door, allow a minimum of 2.5" above unit for models 3, 4, and a minimum of 20.5" for models 6, 8, 12, 16, 24, 32, 40, 48.

** CPC-24 through CPC-48 are available with optional pyramid hoppers, trough hoppers, or dumpster hoppers.

† Based on clean filters.

STANDARD FEATURES & AVAILABLE OPTIONS

TORIT POWERCORE CPC COLLECTORS

TORIT POWERCORE CPV COLLECTORS

	Standard	Optional
Collector Design		
Mild Steel Construction	X	
Clean-Side Filter Pack Removal	X	
Tool-Free Filter Removal	X	
Hopper Access Panel	X	
Sprinkler Taps	X	
Mountable Fan Package (CPC-3 through CPC-24)		X
Stainless Steel Construction		X
Filter Packs		
PowerCore with Ultra-Web	X	
PowerCore AS (Anti-Static) with Ultra-Web		X
Paint System		
Polyester Textured Finish	X	
Hostile Environment Finish		X
Custom Colors, Materials, and Finishes		X
Pyramid Hopper Discharge Options		
Pyramid Hopper	X	
Trough Hopper with High Inlet (CPC-16 through CPC-48)		X
Dumpster Hopper (CPC-16 through CPC-48)		X
Hopper Discharge		
Slide Gate Pack		X
55-Gallon Drum Covers		X
Transitions for Rotary Valves		X
Support Structure		
48" Clearance Beneath Hopper	X	
Leg Extensions		X
Electrical Controls, Gauges and Enclosures		
Control Box NEMA Type 4 with Timer	X	
Solenoid Enclosure NEMA Type 4	X	
Magnehelic®* Gauge	X	
Delta P Control NEMA Type 4 with Timer		X
Delta P Plus Control NEMA Type 4 with Timer		X
Delta P Control (no timer)		X
Solenoid Enclosure NEMA Type 9		X
Heated Solenoid Pack		X
Heavy Duty Cold Climate Kit		X
Photohelic®* Gauge		X
Custom Control Panels		X
Safety Features		
Explosion Vents		X
Sprinkler Pack		X
Platforms and Ladders (CPC 16-48)		X
Electrical Grounding and Bonding		X
Warranty		
10-Year Warranty		X

	Standard	Optional
Collector Design		
Mild Steel Construction		X
Clean-Side Filter Pack Removal		X
Tool-Free Filter Removal		X
Mountable Fan Package		X
Outlet Weatherhood		X
Stainless Steel Construction		X
Vertical Orientation		X
Filter Packs		
PowerCore with Ultra-Web®		X
PowerCore AS (Anti-Static) with Ultra-Web		X
Paint System		
Polyester Textured Finish		X
Hostile Environment Finish		X
Custom Colors, Materials, and Finishes		X
Safety Features		
Electrical Grounding & Bonding		X
Electrical Controls, Gauges and Enclosures		
Control Box NEMA Type 4 with Timer		X
Solenoid Enclosure NEMA Type 4		X
Magnehelic®* Gauge		X
Delta P Control NEMA Type 4 with Timer		X
Delta P Plus Control NEMA Type 4 with Timer		X
Delta P Control (no timer)		X
Solenoid Enclosure NEMA Type 9		X
Heated Solenoid Pack		X
Heavy Duty Cold Climate Kit		X
Photohelic®* Gauge		X
Custom Control Panels		X
Warranty		
10-Year Warranty		X

U.S. Patent US Pat. 7338544, 6235195, 6673136, 6974490, 7090712, 7270692, 6743273, 6924028, 7270693, 7070640 & 7179317; 3,512,559; for use in US Pat. 7338544; AU Pat. Nos. 1284771 & 776588; GB Pat. Nos. 1317317 & 1169109; SG Pats. 95161 & 83229; RSA 2001/6729; PRC 18151655; KS 0603425; EP Pats. 1317317 & 1169109; RU Pats. 2300543 & 2281146; Others Pending

Torit PowerCore, Ultra-Web, Donaldson Torit, and the color blue are registered trademarks of Donaldson Company, Inc.

* Magnehelic and Photohelic are registered trademarks of Dwyer Instruments, Inc.

Information contained in this document is subject to change without notice.

SMARTER PERFORMANCE ON MANY TYPES OF DUST



CPV-2
Weigh belt feeder with limestone dust
(800 cfm)



CPV-2
Day bin with porcelain dust
(800 cfm)



CPC-12
Wood shavings for pet beds
(4000 cfm)



CPV-3
Grain silo bin vent
(1200 cfm)



CPC-12
On wood dust at
furniture manufacturer
(7000 cfm)



CPV-12
Cement silo bin vent conveyor
(3700 cfm)



CPC-3
Powdered milk dust
in cheese factory
(1200 cfm)



LEADING TECHNOLOGY



- Over 1,000 engineers and scientists worldwide
- Over 1,500 issued, active and pending patents
- Broad range of innovative collectors and filters
- 100's of filter media formulations

EXPERIENCE & SERVICE



- Technical expertise and support
- Ready-to-ship filters and parts within 24 hours
- 1,000,000+ dust, fume, and mist collectors installed

GLOBAL SUPPORT



- Facilities in 37 countries
- 40 manufacturing plants and 14 distribution centers
- Sales offices worldwide



**Call Donaldson Torit
to get Cleaner Air today
800-365-1331**

Donaldson.com/ToritPowerCore